

Buick century custom 1999 manual



File Name: Buick century custom 1999 manual.pdf

Size: 4318 KB

Type: PDF, ePub, eBook

Category: Book

Uploaded: 8 May 2019, 20:29 PM

Rating: 4.6/5 from 835 votes.

Download Now!

Please check the box below to proceed.



I'm not a robot



reCAPTCHA
Privacy - Terms

Book Descriptions:

Buick century custom 1999 manual



It also explains the air bag system. You can use it to quickly find Customer Assistance Information This section tells you how to contact Buick for assistance and how to get service and owner publications. It also gives you information on "Reporting Safety Defects" on page 8 Index Here's an alphabetical listing of almost every subject in this manual. GENERAL MOTORS, GM, the GM Emblem, BUICK, the BUICK Emblem and the name CENTURY are registered trademarks of General Motors Corporation. This manual includes the latest information at the time it was printed. We reserve the right to make changes in the product after that time without further notice. If you do this, it will help you learn about the features These mean there is something that could hurt and controls for your vehicle. Many times, this damage would Also, in this book you will find these notices not be covered by your warranty, and it could be costly. For example, These symbols These symbols These symbols Here are some these symbols are important have to do with are on some of are used on other symbols are used on an. You can also learn about some things you should not do with air bags and safety belts. Seats and Seat Controls Rear Seat Passengers Safety Belts They're for Everyone. Manual Front Seat CAUTION You can lose control of the vehicle if you try to adjust a manual driver's seat while the vehicle is moving. Lift the lever to release the seatback, then move the This switch is designed to imitate the movements of seatback to where you want it. Even if you buckle up, your safety belts can't do their job when you're reclined like this. The shoulder belt can't do its job because it won't be against your body. It also tells you some things you should not do with safety belts. It is extremely dangerous to ride in a cargo area, inside or outside of a vehicle. Here's why They work. When you ride in or on anything, you go as fast as You never know if you'll be in a crash. If you do have a it goes. <http://todoferdistribuciones.com.co/userfiles/decatgur-genesis-ii-radar-manual-canada.xml>

- **1999 buick century custom manual, 1999 buick century custom owners manual, buick century custom 1999 manual, buick century custom 1999 manual pdf, buick century custom 1999 manual for sale, buick century custom 1999 manual download, buick century custom 1999 manual transmission, 1999 buick century custom owners manual.**



Get it up to speed. Then stop the vehicle. The rider doesn't stop. In a real vehicle, it could be the windshield. You could be whether you're wearing a safety belt or not. But you can unbuckle a safety belt, even if you're upside down. Adults You may be an excellent driver, but if you're in an This part is only for people of adult size. LapShoulder Belt The driver has a lap shoulder belt. Here's how to wear it properly. 1. Close and lock the door. 2. Adjust the seat to see how, see "Seats" in the Index so you can sit up straight. If the belt isn't long enough, see "Safety Belt Extender" at the end of this section. Make sure the release button on the buckle is positioned so you would be able to unbuckle the safety belt quickly if you ever had to. You can move the adjuster to the height that is right for you. CAUTION You can be seriously hurt if your shoulder belt is too loose. In a crash, you would move forward too much, which could increase injury. The shoulder belt should fit against your body. The shoulder belt is too loose. It won't give nearly as much protection this way. CAUTION You can be seriously injured if your belt is buckled in the wrong place like this. In a crash, the belt would go up over your abdomen. The belt forces would be there, not at the pelvic bones. CAUTION You can be seriously injured if you wear the shoulder belt under your arm. In a crash, your body would move too far forward, which would increase the chance of head and neck injury. Also, the belt would apply too much force to the ribs, which aren't as strong as shoulder bones. CAUTION You can be seriously injured by a twisted belt. In a crash, you wouldn't have the full width of the belt to spread impact forces. If a belt is twisted, make it straight so it can work properly, or ask your dealer to fix it. Like all occupants, they are more likely to be seriously injured if they don't wear safety belts. To unlatch the belt, just push the button on the buckle.<http://www.euroenergetika.lt/media/decatgur-radar-manual.xml>



The belt should go back out of the way. When a safety belt is worn properly, it's more This part explains the air bag system. For pregnant women, as for anyone, the key to making Your vehicle has "Next Generation". If you're too close to an inflating air bag, as you would be if you were leaning You can be severely injured or killed in a crash if forward, it could seriously injure you. Children who are up against, or very close to, any air bag when it inflates can be seriously injured or killed. This is true even though your vehicle has Next Generation frontal air bags. Where are the air bags. The driver's air bag is in the middle of the steering wheel. 122. If your vehicle strikes something that will move or deform, such CAUTION as a parked car, the threshold level will be higher. The air bag is not designed to inflate in rollovers, side If something is between an occupant and an air impacts or rear impacts, because inflation would not bag, the bag might not inflate properly or it. CAUTION In moderate to severe frontal or near frontal collisions, even belted occupants can contact the steering wheel or the instrument panel. Air bags supplement the protection When an air bag inflates, there is dust in the air. When you sit in a center seating position, you have a lap safety belt, which has no retractor. To make the belt longer, tilt the latch plate and pull it along the belt. Accident statistics show that unbelted people in the rear seat are hurt more often in crashes than those who are wearing safety belts. Rear passengers who aren't safety belted can be thrown out of the vehicle in a crash. Here's how to wear one properly. 1. Pick up the latch plate and pull the belt across you. Don't let it get twisted. The shoulder belt may lock if you pull the belt across you very quickly. Pull up on the latch plate to make sure it is secure. When the shoulder belt is pulled out all the way, it will lock. If it does, let it go back all the way and start again.

In a crash, you would move forward too much, which could increase injury. The lap part of the belt should be worn low and snug on the hips, just touching the thighs. When installed on a shoulder belt, the comfort guide pulls the belt away from the neck and head. The elastic the seatback and the interior body to remove the cord must be under the belt. Then, place the guide guide from its storage clip. That includes infants and all children smaller than adult size. Neither CAUTION the distance traveled nor the age and size of the traveler changes the need, for everyone, to use safety restraints. In fact, the law in every state in the United States and in Children who are up against, or very close to, any every Canadian province says children up to some age. This is necessary because an infant's CAUTION neck is weak and its head weighs so much compared with the rest of its body.

In a frontal crash, an infant in a Smaller children and babies should always be rear facing restraint settles into the restraint, so the crash. Secure the baby in an infant restraint. CAUTION Never hold a baby in your arms while riding in a vehicle. What are the different types of add child restraints. When selecting a child restraint, take into consideration not only the child's weight and size, but also whether or not the restraint will be compatible with the motor vehicle in which it will. Rear facing infant restraints are designed for infants of up to about 20 lbs. 9 kg and about one year of age. This type of restraint faces the rear so that the infant's head, neck and body can have the support they need in a frontal crash. These forward facing restraints are designed to help protect children who are from 20 to 40 lbs. 9 to 18 kg and about 26 to 40 inches 66 to 102 cm in height, or up to around four years of age. A booster seat is designed to improve the fit of the vehicle's safety belt system.

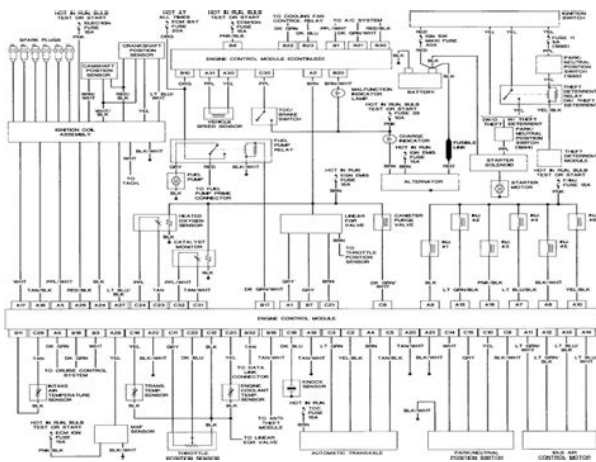

<https://labroclub.ru/blog/02-manual-wap-settings>

If it is, it CAUTION will have a label saying that it meets federal motor vehicle safety standards. A child in a rear facing child restraint can be Then follow the instructions for the restraint. Never secure a child restraint in the center front seat. See the earlier part about the top strap if the child restraint has one. Be sure to follow the instructions that came with the child restraint. The safety belt CAUTION will move freely again and be ready to work for an adult or larger child passenger. A child in a child restraint in the center front seat Securing a Child Restraint in the Center can be badly injured or killed by the right front. It will be ready to work for an adult or larger CAUTION child passenger. Securing a Child Restraint in the Right A child in a rear facing child restraint can be Front Seat Position seriously injured or killed if the right front passenger's air bag inflates, even though your. You'll be using the lap shoulder belt. See the earlier part about the top strap if the child restraint has one. Be sure to follow the instructions that came with the child restraint. You may find it helpful to use your knee to push down on the child restraint as you tighten the belt. Accident statistics show that children are safer if they are restrained in the rear seat. Here two children are wearing the same belt. The belt can't properly spread the impact forces. In a crash, the two children can be crushed together and seriously injured. A belt must be used by only one person at a time. Here a child is sitting in a seat that has a shoulder belt, but the shoulder part is behind the child. If the child wears the belt in this way, in a crash the child might slide under the belt. The belt's force would then be applied right on the child's abdomen. If you've had a crash, do you need new belts. But if a safety belt isn't long enough to fasten, your After a very minor collision, nothing may be necessary.

<http://dieter-sauter.com/images/bose-lsps-speaker-system-manual.pdf>

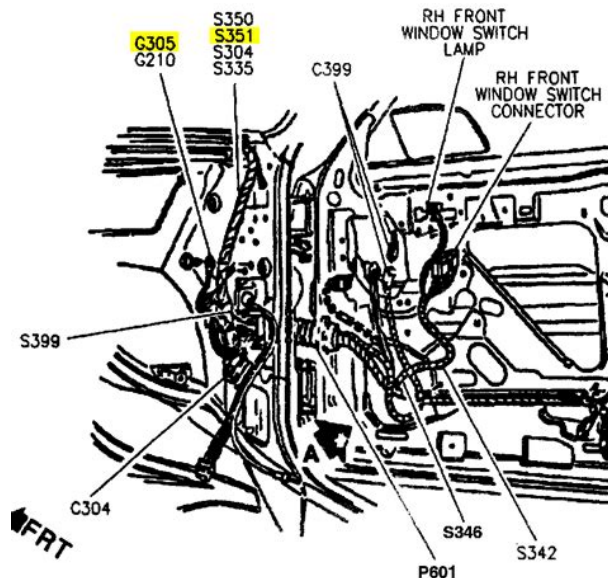

Also explained are the instrument panel and the warning systems that tell you if everything is working properly and what to do if you have a problem. A child or others could be badly injured or even killed. They could operate power windows or other controls or even make the vehicle move. Don't leave the keys in a vehicle with children. Your ignition only. dealer or Buick Premium Roadside Assistance has the code for your keys. If you need a new ignition or door key, contact your. Passengers especially children can easily open the doors and fall out. When a door is locked, the inside handle won't open it. Outsiders can easily enter through an unlocked door when you slow down or stop your vehicle. This may not be so obvious You increase the chance of being thrown out of the vehicle in a From the inside, to lock or unlock the door manually,. Mode 2 Automatic all door lock when the transaxle is Press the power door lock shifted out of PARK P; no automatic door unlock.Insert Remember, this feature can't guarantee that you'll never your key into this lock and turn it upward. This will be locked out of your vehicle. If you use the manual engage the safety lock. Operation Operation is subject to the following two conditions 1 this device may not cause interference, and 2 this Press UNLOCK once to device must accept any interference received, including unlock the driver's door and interference that may cause undesired operation of to turn on the interior lamps. Your Mode 3 Headlamp Flash only vehicle's ignition must be off for the Instant Alarm to work. This feature also ignition key in RUN provides a brief time period after all the doors are Press and hold the power door unlock switch. The Delayed Locking feature will lock the Locking feature. When replacing the battery, use care not to If a transmitter is lost or stolen, a replacement can be touch any of the circuitry. Gently pry apart the front method used by this remote keyless entry system. The and back.

<https://difumarket.com/images/bose-ls-18-manual.pdf>



You can also press the car symbol on your CAUTION remote keyless entry transmitter. Theft It can be dangerous to drive with the trunk open Vehicle theft is big business, especially in some cities. Remember to keep your valuables out of sight. In an emergency, call the Buick Premium Roadside Assistance Center at 1112. In Canada, call 1 6800. To use ACC, push in the key and turn it toward you. Leaving children in a vehicle with the ignition Your steering wheel will stay locked. If you do, you could damage the so, is it all the way in. If it is, then turn the transaxle. Try pushing your accelerator pedal all the way to the floor and holding it there as you hold the key in START for up to 15 seconds. The answer depends on the outside temperature, the 1. Turn off the engine. Instead of trying to list everything here, we ask that you contact 2. To be sure your improper operation. CAUTION NOTICE Shifting out of PARK P or NEUTRAL N while your engine is "racing" running at high speed is Shifting to REVERSE R while your vehicle is dangerous. Unless your foot is firmly on the moving forward could damage your transaxle. You can use SECOND 2 on hills. but lower fuel economy than SECOND 2. You can It can help control your speed as you go down steep use it on very steep hills, or in deep snow or mud. To set the parking brake, hold the regular brake pedal down with your right foot. Your vehicle can roll. If you have left the engine running, the vehicle can move suddenly. Your vehicle could move suddenly if the shift lever is not fully in PARK P with the parking brake firmly set. And, if you leave the vehicle with the engine running, it could overheat and even catch fire. Then move the shift lever out of PARK P. If you ever hold the brake pedal down but still can't shift out of PARK P, try this 1. But if you CAUTION ever have to, here are some things to know. Engine exhaust can kill. It contains the gas carbon monoxide CO, which you can't see or CAUTION smell. Your vehicle can roll.

Don't leave your vehicle when the engine is running unless you have to. This switch is labeled AUTO. Tap the rear of Steering Column the switch, and the driver's window will open a small amount. If the rear of the switch is pressed all the way A tilt steering wheel allows down, the window will go all the way down. To signal a turn, move the lever all the way up or down. When the turn is finished, the lever will return automatically. The The LOW WASH light on closer to LO, the shorter the delay between wipes. When you apply your brakes, the cruise control CAUTION shuts off. If you leave your cruise control switch on when CAUTION you're not using cruise, you might hit a button and go into cruise when you don't want to. They control these systems When going up steep hills, you may have to step on the Headlamps accelerator pedal to maintain your speed. When it's dark enough outside, your front turn signal lamps will turn off and your vehicle's headlamps and A warning chime will sound if you open the driver's parking lamps will turn on. With Theater Dimming, the lamps don't just timed illumination period will be canceled and the turn off at the end of the delay time. Instead, they slowly interior lamps will remain on since a door is open. To choose either the left or right outside mirror, move the top switch from left through neutral to right. This A convex mirror can make things like other feature is controlled by the on and off settings on the vehicles look farther away than they really are. Push on the right side You may also have an armrest located within the center of the door. The ashtray will then rotate to the right for back seat of your vehicle. You electrical equipment to your vehicle. It is located on the can also move them from side to side. The visors also passenger's side of the vehicle, under the glove box, and have extenders that you can pull out for added coverage.

<https://michaels-limo.com/wp-content/plugins/formcraft/file-upload/server/content/files/1626c551278fb8--canon-a2000-is-manual-pdf.pdf>

The To close the astrorroof, push and hold the front of the control switch is located overhead on the headliner. The sunshade can only be closed by hand. OnStar Option Your vehicle's electrical wiring will accommodate. You'll know how fast you're going, about how much fuel is in your tank and many other things you need to drive safely and economically. 249. Your odometer shows how far your vehicle has been driven in Warning Lights, Gages either miles used in the United States or in

kilometers. If it will come on briefly when doesn't come on then, have you turn on the ignition, as it fixed so it will be ready a check to show you it's to warn you if there's. The on briefly when you turn the ignition key to RUN. If the light will stay on if your parking brake doesn't release light doesn't come on then, have it fixed so it will be fully. Adjust your driving accordingly. If the gage is low on coolant and the pointer moves into the red engine may overheat. Oil Warning Light As your engine starts to run out of fuel, your engine may If you have a problem with not run as efficiently as designed since small amounts of your oil, this light may stay air are sucked into the fuel line causing a misfire. The CHANGE OIL SOON See "PASS Key II" in the Index. All Low Fuel Light these things are normal and do not indicate that anything If your fuel is low, a circular is wrong with the fuel gage light on your instrument At the gas station, the pump shuts off before the gage panel will come on and reads FULL F. Be sure to read about the particular systems supplied with your vehicle. Comfort Controls FM Stereo with Cassette Tape and Manual Single Zone Climate Control Compact Disc Player with Automatic Tone. Turn this knob toward red clockwise for warmer air. Turn it toward blue counterclockwise for cooler air. Mode Knob The right knob has several settings to control the direction of airflow.

BANGLNHOSPITAL.COM/UserFiles/File/connecticut-electric-30-amp-6-circuit-manual-transfer-switch.pdf

Half of the air is directed through the On very hot days, open the windows long enough to let instrument panel outlets. Most of the remaining air is hot, inside air escape. The system will bring in outside air, heat it and send it to the floor ducts. The air The center knob sets the temperature for the driver's conditioning compressor will run automatically in this outlets. Some of lever all the way in the red area. The system will bring the air goes to the floor ducts and the side window vents. If the DUAL button light is lit, this master temperature control sets the temperature for the driver only. The indicator light will be lit when recirculation is engaged, but will light for one second and then turn off if selected when not permitted. NOTICE Don't use a razor blade or anything else sharp on the inside of the rear window. If you do, you could cut or damage the warming grid, and the repairs wouldn't be covered by your warranty. The heater and to operate easily and give years of listening pleasure. To change what is normally shown on the display station or time, press the knob until you see the display you want, then hold the knob until the display flashes. You can set up to BASS Press this knob lightly so it extends. Turn the 18 stations six AM, six FM1 and six FM2. Just knob to increase or decrease bass. To change If Equipped what is normally shown on the display station or time, press the knob until you see the display you want, then hold the knob until the display flashes. You can set up to BASS Press this knob lightly so it extends. Just knob to increase or decrease bass. If your radio radio. AMFM Stereo with Cassette Tape Player The display will show either OFF or ON for a few and Automatic Tone Control If Equipped seconds when you press the button. Dolby Noise Reduction is manufactured under a license from Dolby Laboratories Licensing Corporation. You can set up to VOLUME Press this knob to turn the system on and 18 stations six AM, six FM1 and six FM2.

Just off. Turn the stations on your preset buttons depending on which knob to move the sound to the left or right speakers. Note that the selection on the tape. Your tape must have at least three cassette tape adapter kits for portable compact disc seconds of silence between each selection for PREV to players will work in your cassette tape player. AMFM Stereo with Cassette Tape and The double D symbol will appear on the display. Compact Disc Player with Automatic Tone Control If Equipped Dolby Noise Reduction is manufactured under a license from Dolby Laboratories Licensing Corporation. To change what is you return to your favorite stations. You can set up to normally shown on the display station or time, press 18 stations six AM, six FM1 and six FM2. Turn the stations on your preset buttons. AUTO SET will flash knob to move the sound to the left or right speakers. The SEEK down and up arrows will also find the previous and next selections on the tape.

If E and a number appear on the radio display, the tape won't play because of an error. 3 Press this button to reverse the tape rapidly. Press the If you're driving on a very rough road or if it's very hot, button near the CD slot to remove a disc. Press the the disc may not play and an error code may appear on button near the tape slot to remove a tape and the radio the display. You will hear sound. The instructions which follow explain how to enter your The display will show REP to let you know that you secret code to activate the THEFTLOCK system. You will have to wait an hour with the with your code. When you try again, 6. If a cassette tape or compact disc is playing, press this If Equipped button to stop it and the radio will play. If your vehicle has this feature, you can control certain radio functions using the buttons on your steering wheel. Increase volume slowly until you hear comfortably The range for most AM stations is greater than for FM, and clearly.

The longer range, however, can cause stations to interfere with each other. Store them in their original cases Your AM FM antenna is integrated with your rear or other protective cases and away from direct sunlight window defogger, located in the rear window. Be sure and dust. There is enough space between the lines to Do not try to clear frost or other material from attach a cellular telephone antenna without interfering the inside of the rear window with a razor blade. We've also included many other useful tips on driving. Defensive Driving City Driving Drunken Driving Freeway Driving Control of a Vehicle Before Leaving on a Long Trip Braking. Anticipate what they might do. But what if people do. How much is "too much" a national tragedy. The law in many U.S. states sets the legal limit at a BAC of 0.10 percent. No amount of coffee or number of cold CAUTION showers will speed that up. "I'll be careful" isn't the right answer. What if there's an emergency, a need to Drinking and then driving is very dangerous. They are the brakes, the steering and reaction time. Some people drive in AntiLock Brakes ABS spurts heavy acceleration followed by heavy Your vehicle has anti lock brakes ABS. ABS is an braking rather than keeping pace with traffic. The computer is programmed to make the most of available tire and road conditions. Here's how anti lock works. Let's say the road is wet. You're driving safely. If you get too close to the vehicle in Traction System is limiting front of you, you won't have time to apply your brakes wheel spin. The Enhanced to let you know if there's Traction System warning light should go off. a problem. Under less the news happen on curves. Here's why favorable conditions you'll want to go slower. Experienced driver or beginner, each of us is subject to the If you need to reduce your speed as you approach a same laws of physics when driving on curves. An emergency like this requires close attention and a quick decision.

If you are holding the steering wheel at the recommended 9 and 3 o'clock positions, you can turn it a full 180 degrees very quickly without removing either hand. For one thing, The driver of a vehicle about to pass another on a following too closely reduces your area of vision, lane highway waits for just the right moment, especially if you're following a larger vehicle. Keep trying to steer and start your left lane change signal before moving out constantly seek an escape route or area of less danger. When you are far enough Skidding ahead of the passed vehicle to see its front in your inside mirror, activate your right lane change signal. For safety, you'll want to slow down and adjust your driving to these conditions. It is important to slow down on slippery surfaces because stopping distance will be longer and vehicle control more limited. They may cut down on glare from headlamps, but they also make a lot Drive defensively. Don't drink and drive. You can be temporarily blinded by approaching Adjust your inside rearview mirror to reduce the headlamps. On a wet road, you can't stop, accelerate or turn as well because your tire road traction isn't as good as on dry roads. And, if your tires don't have much tread left, you'll get even less traction. They won't work as well in a quick stop and may cause pulling to one side. You could lose control of the vehicle. After driving through a large puddle of water or a car wash, apply your brake pedal lightly until your brakes work normally. So much water can build up under your tires that they can actually ride on the water. NOTICE This can happen if the road is wet enough and you're going fast enough. When your vehicle is hydroplaning, If you drive too quickly through deep puddles or it has little or no

contact with the road. Get a city map and plan your trip into an unknown part of the city just as you would for a cross country trip.

If you have a clear view of the freeway as you drive along the entrance ramp, you should begin to check traffic. Try to determine where you expect to blend with the flow. They'll be Maps Do you have up date maps.Or is it just plain falling asleep at the wheel. Call it highway hypnosis, lack of awareness, or whatever. There is something about an easy stretch of road with the same scenery, along with the hum of the tires on the road, the drone of the engine, and the rush of the wind against the vehicle that can make you sleepy. Keep your vehicle in good shape. Check all fluid Coasting downhill in NEUTRAL N or with the levels and also the brakes, tires, cooling system and ignition off is dangerous. But wet Most of the time, those places where your tires meet the ice can be even more trouble because it may offer the road probably have good traction. Even though you have the anti lock braking system, you'll want to begin stopping sooner than you would on dry pavement. CAUTION Put on extra clothing or wrap a blanket around you. If you have no blankets or extra clothing, make body Snow can trap exhaust gases under your vehicle.Start the engine again and repeat this only when you feel really uncomfortable from the cold. But do it as little as possible. Preserve the fuel as long as you can. It tells you the gross weight capacity of your vehicle, called the Gross Two labels on your vehicle show how much weight it Vehicle Weight Rating GVWR. If you do, parts on your vehicle can a crash. To identify what the vehicle trailering capacity is for your vehicle, you should read the information in "Weight of the Trailer" CAUTION that appears later in this section. You'll find these numbers on the and your trailer. Cross the safety chains under the tongue Tire Loading Information label found inside the trunk of the trailer so that the tongue will not drop to the road.

If the trailer has Then, to move the trailer to the left, just move that hand electric brakes, start your vehicle and trailer moving and to the left. Check with your CAUTION dealer. The arrows on your instrument panel will flash whenever you signal a turn or lane change. See the Maintenance Schedule for more 1. Apply your regular brakes and hold the pedal down on this. Hazard Warning Flashers Cooling System Other Warning Devices If a Tire Goes Flat Jump Starting Changing a Flat Tire Towing Your Vehicle Compact Spare Tire Engine Overheating. Your hazard warning flashers work no matter what position your key is in; they even work if the key isn't in the ignition. But please follow the steps below to do it safely.If they are, it could cause a ground connection you don't want. You wouldn't be able to If you leave your radio on, it could be badly start your vehicle, and the bad grounding could damaged. People have been hurt doing this, and some have been blinded. Use a flashlight if you need more light. Be sure the battery has enough water. You don't need to add water to the ACDelco Freedom battery installed in every new GM vehicle. If they do, you could get a shock.Remove the cables in reverse order to prevent negative cable to the electrical shorting. Take care that they don't touch good battery's each other or any other metal.To help avoid serious personal injury to you or others With current trends in automotive styles and design, it is Never let passengers ride in a vehicle that is essential that the correct towing equipment is used to tow a being towed. See After driving in the overheated engine protection "Engine Coolant Temperature Gage" and "Engine operating mode, to avoid engine damage, allow Coolant Temperature Warning Light". Stay away from the engine if you see or hear steam coming from it. Just turn it off and get everyone away from the vehicle until it cools down. Just to be safe, drive slower for about 10 minutes.

<http://eco-region31.ru/02-manual-wap-settings>