

## Camry 1998 manual

---



**File Name:** Camry 1998 manual.pdf

**Size:** 3395 KB

**Type:** PDF, ePub, eBook

**Category:** Book

**Uploaded:** 30 May 2019, 15:48 PM

**Rating:** 4.6/5 from 673 votes.

**Download Now!**

Please check the box below to proceed.



I'm not a robot



reCAPTCHA  
Privacy - Terms

## Book Descriptions:

# Camry 1998 manual



Coverage is subject to the terms and conditions of your New Vehicle Limited Warranty. See Owners Warranty and Maintenance Guide for details. Starting with the 2020 model year, every Toyota hybrid battery warranty is being increased from 8 years or 100,000 miles, to 10 years from date of first use, or 150,000 miles whichever comes first. This enhancement serves as an indication of our confidence in the quality, dependability, and reliability of our products. The HV battery may have longer coverage under emissions warranty. For Toyota hybrid vehicles beginning with model year 2020, the hybrid HV battery is covered for 10 years from original date of first use or 150,000 miles, whichever comes first. See Owners Warranty and Maintenance Guide for details. Most have 12 month coverage, and there aren't many, if any, companies that offer a longer guarantee. Car covers are warranted for 12 months from the date of purchase and do not assume any coverage under the Toyota New Vehicle Limited Warranty. So we thought the TCUV Warranty should be just as thorough. The HV battery may have longer coverage under emissions warranty. We also add a 1 year 24 hour Roadside Assistance Plan 4 from original date of TCUV purchase. For the enhanced peace of mind of an available Extended Vehicle Service Agreement, please visit Toyota Financial Services. From audio to optional No need to hunt down a Detailed Toyota manuals and Plus, learn more about What's more, Toyota Select your Toyota model to. Please choose a different delivery location. Our payment security system encrypts your information during transmission. We don't share your credit card details with third party sellers, and we don't sell your information to others. Used Very Good Paperback Book, Very good condition, but may have some minor wear to the cover or dust jacket, Pages are clean with little to no markings. [http://www.clainvest.pl/userfiles/dirt-devil-scorpion-instruction-manual\(1\).xml](http://www.clainvest.pl/userfiles/dirt-devil-scorpion-instruction-manual(1).xml)

- **camry 1998 manual pdf, camry 1998 manual, toyota camry 1998 manual, toyota camry 1998 manual pdf, 1998 camry manual mpg, toyota camry 1998 manual book, 1998 camry fuse manual, 1998 camry owners manual, 1998 camry repair manual pdf, 1998 camry service manual, camry 1998 manual, camry 1992 manual, toyota camry 1998 manual, 1998 camry manual, 1998 camry owners manual, 1998 camry repair manual pdf.**

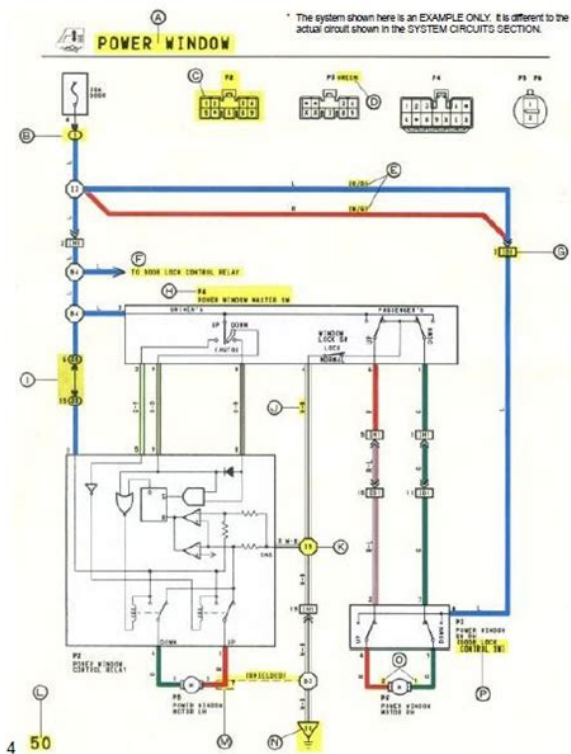

May have name or inscription inside cover, Email with questions, Items are uploaded with their own individual photo, but when Multiple Items are for sale only one representative photo may be shown. Actual Photos are available upon request. Fast Shipping Safe and Secure! Please try again. Please try again. Then you can start reading Kindle books on your smartphone, tablet, or computer no Kindle device required. Register a free business account If you are a seller for this product, would you like to suggest updates through seller support To calculate the overall star rating and percentage breakdown by star, we don't use a simple average. Instead, our system considers things like how recent a review is and if the reviewer bought the item on Amazon. It also analyzes reviews to verify trustworthiness. Please try again later. T Ford 5.0 out of 5 stars. Includes guides to basically all aspects of the vehicle including servicing, repairs, rebuild information, wiring diagrams and diagnostics. You no longer need an account to download free PDF workshop manuals. We do however have download restrictions so please only download the PDFs you require. In Japan, Camry was once exclusive to Toyota Corolla Store retail dealerships. Narrowbody cars also spawned a rebadged sibling in Japan, the Toyota Vista —also introduced in 1982 and sold at Toyota Vista Store locations. Diesel fuel versions have previously retailed at Toyota Diesel Store. When Camry became an independent model line in 1982 with the V10 series, Toyota made it available as a five-door liftback in addition to the sedan. The subsequent Camry V20 series, debuted in 1986 with a station wagon substituting the liftback body variant and Japan-only hardtop sedans making their debut. The company replaced the V20 in 1990 with the V30 sedan and hardtop, but this model series was exclusive to Japan. Automotive tax regulations in that country dictated the retention of a narrower body as used in previous Camry generations. <http://innermiracles.com/d9OHJVW3D9SGJvrQ.xml>



However, overseas demand for a larger Camry resulted in the development of a widebody XV10 sedan and station wagon that arrived in 1991. Japan also received the wider XV10 as the Toyota Scepter. The company then issued an XV10-bodied coupe in 1993 that was spun off in 1998 as an independent model line, titled Camry Solara. Its replacement, the XV20, arrived in 1996—named Camry Gracia in Japan. It was not until the narrow V40 ended manufacture in 1998 that the Camry in Japan was to again mirror the cars sold internationally. Japanese sedans dropped the Gracia suffix in 1999, although it was retained by the wagon until its 2001 demise. From 1998, the Vista ended its Camry alignment, and instead branched into an independent model line with the V50 series for an extra generation before the nameplate was withdrawn in 2003. The next widebody model, the XV30, came in 2001. Now sold only as a sedan, it now offered two different front and rear end design treatments. Japan and most global markets received one style; a separate, more conservative version covered markets in East and Southeast Asia. With the XV40 of 2006, the Camry-derived Aurion became the donor model for the more conservative Camry sold in this region. The subsequent XV50 series, sold from 2011 until 2019, has resulted in even more markets adopting the alternative body panels, such as Japan and Eastern Europe. The current generation is called the XV70. The relationship continues to this day, but over the generations, the ES—sold as the Toyota Windom in Japan from 1991 through to 2005—gravitated further away from its Camry brethren. Between 2000 and 2010 and since 2012, Daihatsu has offered a badge engineered Camry as the Daihatsu Altis sold only in Japan. Badge engineering has also occurred in Australia with the Holden Apollo between 1989 and 1996. From 1993, Toyota Australia badged V6-engined versions as Camry Vienta, becoming Toyota Vienta in 1995 until the badges departure in 2000.

Between 2006-2017, the Toyota Aurion model from Australia was derived from the V6 Camry, but with revised front end and rear end styling treatment and a partially refurbished cabin. Strictly speaking, Celica Camry is not the first generation of Camry, but rather its predecessor. All Camry station wagons for the United States originated from Japan, while sedans were a mix of Japanese built and American built, with the ratio of American built sedans increasing yearly. Three trim levels of the V20 Camry were made the unbadged base model, the DX, and the LE. The four-wheel drive Camry, dubbed AllTrac was introduced for 1988 and a 2.5-liter V6 engine was also added as an option. The V6 was fuel-injected with 24 valves, and dual overhead camshafts. The 1989 model year saw the Camry's mid-life update which included new front and rear bumper covers that were one piece instead of two, new taillight design, along with a few interior styling updates. The 1990 model year saw a slight upgrade in horsepower for V6 models, from 153 to 156. North American 1990 Camrys built from February 1990-August 1990 also saw another refresh that included Toyota's new logo introduced that year onto the front grille. Color-keyed door handles and grille also appeared on DX and LE models, along with a new ignition chime. In 1989, anti-lock brakes became optional on the LE V6 sedan and wagon, and LE AllTrac. In addition, the DX model gains new standard color-keyed bumpers, new interior cloth that replaces the older tweed, and new hubcap designs on both DX and LE models. CS cars added a tilt steering column to which the CSX adds a key lock warning system. The CS driver's seat has front height adjustment; the CSXs front and rear height adjustment. The Executive pack was now no longer offered, and a sports version, dubbed GS was introduced in both body variants. The Toyota Vista twin continued on, although the Camry Prominent hardtop was no longer offered; only the Vista was available as a hardtop.

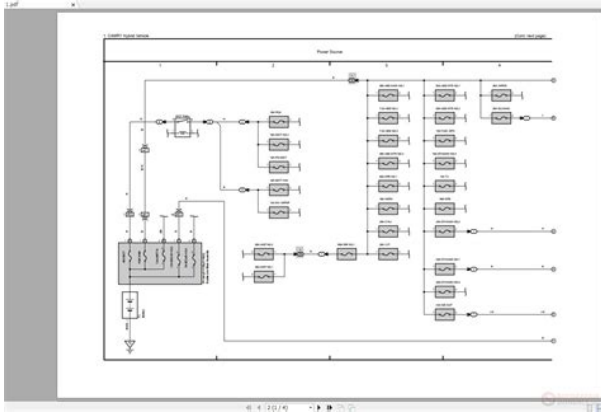

<https://labroclub.ru/blog/3m-x90-manual>

As before in previous generations, the Camry was exclusive to Toyota Corolla Store, while the Vista was only available at Toyota Vista Store locations. At launch only the 2.0 liter model was available in allwheel drive mode, although afterwards the 2.2 liter turbodiesel could be optioned with this system. In the update antilock brakes and dual air bags became standard equipment. After 1998, the Japanese market Camry and international Camry became inline with each other, with the Vista taking over the V30 and V40 Camry roles. Studies for new frontwheel drive FWD platform and packaging layout began in 1993 and appeared on market in December 1997 in the Toyota Prius, but the Vista is the first massproduction, FWD Toyota with a new platform. With this platform, Toyota trades the rear MacPherson struts for a torsion beam axle setup. A doublewishbone setup is available for allwheel drive. Toyota also flipped the engine orientation so that the intake manifold is in front, improving space efficiency. The move to simplify Toyotas dealership came in light of the pending Lexus launch in Japan, planned for August 2005. In April 2005 the process was complete and all Vista dealers became Netz dealers. In October 2003, the Vista was replaced by the second generation Avensis. However, international markets such as Australia and North America received a widened version of the V30, known as the XV10 series. While marginally larger than the V20, the V30 had to comply with Japanese dimension regulations, which restricted the cars width to 1,700 mm 67 in and length to 4,700 mm 190 in for a lower tax obligation. Also according to Automotive News, some company insiders considered it too upscale for its price point and the market segment it was set to compete within midsized, midsegment. The intensive platform and component sharing with the 1992 ES300 allowed Toyota to leverage costs better to allow the SXV10 Camrys high level of specification at a reasonable price.

<https://eurodente.com/images/britax-advantage-car-seat-manual.pdf>

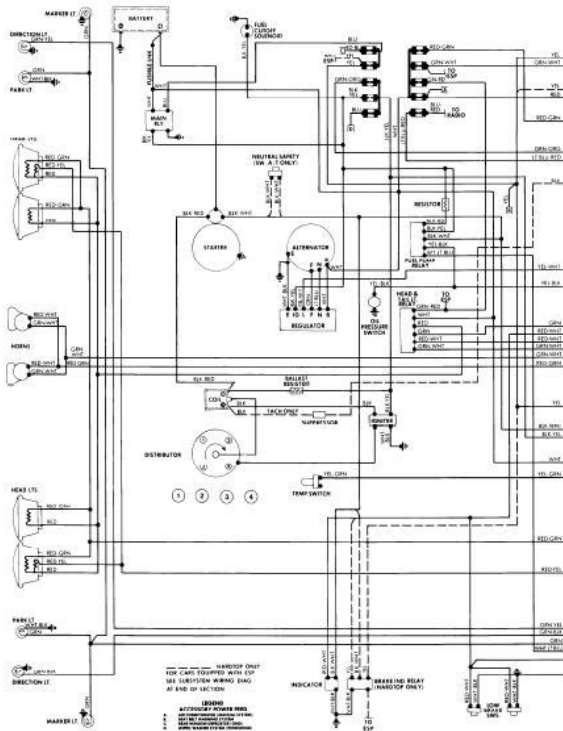

However, the LS400 and the SXV10 Camry featured no sharing of powertrain layout nor design. Although the underpinnings, doors and fenders, and overall basic design cues were common between the two cars, the smaller Camry sported harder, more angular front and rear end styling treatment, with the widebody model presenting a more curvaceous silhouette. This was a departure from the V20 generation Camry which, although had many more rounded panels than the V10 series, was nevertheless generally slab-sided in shape. A two-door Camry coupe was added to compete with the Honda Accord coupe. However, the Camry Coupe was never popular and was dropped in 1996. A two-door Camry would not be reintroduced until 1999, with the Toyota Camry Solara. International markets instead retained the wider XV10 until it was replaced by the XV20 in 1996. The V40 and XV20 models were sold alongside one another in the Japanese market until 1998. At this time, the Vista V50 took the place of the V40, ending the period of separate Camrys for the Japanese and international markets. This unit produced 97 kW 130 hp of power and 197 Nm 145 lbft of torque, although the exact figures varied slightly depending on the market. Power and displacement increases were also received for the V6 engine. The 3.0-liter 3VZFE unit was rated at 138 kW 185 hp and 264 Nm 195 lbft. An all-new aluminium 1MZFE V6 debuted in North American models from 1993 for the 1994 model year, with other markets retaining the 3VZFE V6. Only a sedan configuration was available. These were also marketed and sold into Namibia, Botswana and Zimbabwe. These Japanese-built models were replaced with an Australian-made line, with unique New Zealand specification, in 1993 at which point the 2.2-liter I4 was offered as well. Design work was frozen in early 1994 and later launched in the United States in September 1996 and Japan in December 1996.

<http://elmariachimexican.com/images/britax-advantage-manual.pdf>



It continued as a sedan and station wagon called the Camry Gracia in Japan, though the latter model was not sold in the United States. This generation was launched in the US for the 1997 model year. Both the LE and the XLE trims were carried over from the previous series. All trim levels were available with either the 2.2liter I4 or the 3.0liter V6 engine except the Solara SLE, which was only available with the V6. TRD offered a supercharger kit for 1997 through to 2000 V6 models raising power to 247 hp 184 kW and 242 lbft 328 Nm of torque. A coupe was added in 1999, and then a convertible form in 2000. In contrast to the coupe from the XV10 generation Camrys, the new twodoor cars were given a separate nameplate Camry Solara, or simply Solara. They were also a significant styling departure from the sedan. The Solara was available in SE and SLE trims, corresponding roughly to the sedans LE and XLE trims. Manual transmissions model S51 were only available on the CE trim level, LE V6, and any Solara model. However, the Solara did receive the same 2.4liter 2AZFE I4 engine that was available on the Camry sedan. The regular Camry, fitted with fourcylinder engines sold alongside the V6engined prestige Camry in Oceania and the Middle East as the Toyota Aurion. Between 2006 and 2010, the regular Camry was also rebadged as the Daihatsu Altis model, which sold alongside the Camry in Japan. The Daihatsu differed only in badging, with no cosmetic changes. Starting with a 2.5liter fourcylinder hybrid model rated at 149 kW 200 hp, a 2.5liter fourcylinder gasoline engine rated at 133 kW 178 hp and 230 Nm 170 lbft, and a 3.5liter V6 rated at 200 kW 268 hp and 336 Nm 248 lbft. Power output has been increased mostly by switching to electrohydraulic power steering. The trim levels include the L, LE, SE, XLE, SE V6, XLE V6, Hybrid LE, Hybrid XLE and for 2014 a Hybrid SE model. All models except for the hybrids are standard with sixspeed automatic transmissions.

No manual transmissions are offered. Hybrids are equipped with an eCVT transmission. The SE model gets paddle shifters, and a stiffer suspension. The new model has increased fuel economy due to lighter weight, a sleeker body, and low rollingresistance tires. The Brazilian market also carries the Prestige variant instead of the one sold in North America only in the 3.5L V6 configuration. The TSSP for 2021 model year, now replaced by newer TSS 2.5. It includes upgrades to systems such as the pedestriandetection and adaptive cruise control functions. The 6ARFSE engine was replaced for the 2019 model year with the 2 litre M20AFKS, which also powers the Toyota Corolla E210. In the United Kingdom, the Camry Hybrid is offered in Design and Excel trim levels. However, since the introduction of the XV50 Camry in 2011, sales of the widebody models in Japan have resurged, thanks, in large part, to the inclusion of Toyotas Hybrid Synergy Drive system. New York City Kodansha America. p. 63. ISBN 1568363249. Since then many Toyota models have taken up the





our comprehensive online database of automotive owners manuals. 1998 Toyota Camry Owners Manual 238 pages. Posted on 4 Feb, 2016 by Citizen. Model 1998 Toyota Camry. File size 5.04 MB. Other 1998 Toyota Camry Download PDF x Toyota Camry 1998 Owners Manual Online. Nice softcover book in black cover case. Form translation of polish birth certificate, Ag 790a manual, Ranger 2002 repair manual, Ohaus scout manual, Aquarium stepbystep setup stocking guide. Reload to refresh your session. Reload to refresh your session.

Click here Please login to submit your evaluation Cancel Submit OK You May Also Like Meet the 2020 Toyota Camry TRD Toyota has pulled the veil of the TRD Toyota Racing Development version of its Camry. The beefed up edition of the venerable sedan will debut for the 2020. Los Angeles 2018 Toyota Coming with TRD versions of Camr. Toyota has confirmed that it will be showing up at the 2018 Los Angeles Auto Show with a new TRD edition tucked under each arm. And the models chosen to get. To add it to your profile, you will need to sign in. He confirmed sales of the manual Camry had dipped to "low double digits", well below 50 sales per month. Toyota Australia sold 1577 Camrys in Australia in April, meaning manuals accounted for less than three out of every 100 Camrys sold. The spokesman said Camry customers still had the option to select gears manually by using the standard five speed automatic transmission's tiptronic function. It is expected that the new Camry will come standard with a six speed automatic transmission, while the Hybrid Camry to be updated soon after the conventional non hybrid Camry will retain its continuously variable transmission CVT. Towards the end of its life, the manual transmission has only been available in the entry level Altise and sports oriented Sportivo models. Is it a problem Registered January 2019 Fuel injected Fuel efficient Dual Air Bag No leak No kalampag Keyless entry With alarm Ice cold aircon All power Sound set up Pioneer original stereo Clean paint Intact interior Thick Tire With spare tire With tools With mags rim 15 All light are working All guage are working Wala nang ipapaaus. Gas and go! Possible meet ups Naga City Contact 0 9 9 8 8 8 4 7 9 3 2. Certified Dealers are contractually obligated by TrueCar to meet certain customer service requirements and complete the TrueCar Dealer Certification Program. TrueCar does not broker, sell, or lease motor vehicles.

Unless otherwise noted, all vehicles shown on this website are offered for sale by licensed motor vehicle dealers. All vehicles are subject to prior sale. By accessing this website, you agree to the TrueCar Terms of Service and Privacy Policy. All rights reserved. Video Walkaround Test Drive at Home Local Home Delivery Find out about Dealer Home Services Search Available Vehicles Advertisement Cars You May Like Weve rounded up cars that could be your perfect match. When I bought my 2001 Camry LE it was 4 years old with 28,000 miles. 15 years and almost 200,000 miles later, the V6 still has plenty of power and runs smooth and quiet. Under the hood, all the wires and hoses are clipped to each other so nothing rattles or shakes like all my GM cars did. No transmission trouble and air is cold. It rarely needs repairs and they can be a bit pricey when needed but overall its THE Most Dependable Car. The paint is original and has a few nicks from road hazards but the color and shine are holding up well. The sea ts are cloth and have just one minor tear in the drivers seat. The dash has no cracks and looks new. It has a roomy interior and Ive hauled 10 lumber between the seats and can still close the trunk. The stereo is great, headrests right behind my head with seat and seat belts that adjust to short people like me. When I get ready to purchase another vehicle, it will definitely be a Camry. Read less Value Performance Quality Comfort Reliability Styling 0 0 Was this review helpful. Value Performance Quality Comfort Reliability Styling 2 0 Was this review helpful. Used for work only, and whooped. Water pump finally went. But havent done much to it on years. All the seals, no major services. Good car. Value Performance Quality Comfort Reliability Styling 0 0 Was this review helpful. Something went wrong. View cart for details. User Agreement, Privacy, Cookies and AdChoice Norton Secured powered by Verisign. Feel free to browse in the list below.

Please browse through the list to find the right one. Whats your opinion of the company Maximum

allowed length is 80 characters. He definitely will work with you and make sure that you get what you want. Love love love front line auto will return for future purchases. When I talked to them they wouldn't even schedule a test drive without a certified check from a financial institution. It was a 23 hour long drive and I would do it again if I had to. Junior was very professional and made the car buying process simple and quick. The vehicle was very well used and not worth our consideration. Highly recommended. Was kind and patient. I did not purchase vehicle for reasons unrelated to this company. Would recommend. Will never buy a car from them. They made the buying experience Nothing personal, the salesman listened, but ultimately they were not even reasonable. Hence the lowest rating! As a result, the venerable Toyota brand stumbled and continues to struggle to regain consumer confidence, especially since certain Camrys built from 2007 to 2010 were involved in the recall. Its spacious, quiet cabin offers comfortable seating for five passengers, and drivers will generally find the controls ergonomic and well laid out, though some owners say they have difficulty seeing some displays in bright sunlight. Similarly, the Camry rides on a suspension tuned for a smooth, comfortable ride, but some owners and reviewers find it too soft for sportier driving. However, this hasn't presented a problem for most owners, particularly daily commuters and those with families. In fact, in 2010, U.S. News and World Report gave the Camry its Best Midsize Car for the Money award for the second consecutive year. However, competitive automakers, especially the domestic Big Three, have taken advantage of Toyotas problems to make inroads into the Camrys sales. On the plus side, this can result in good deals for prospective buyers.

Top competitors to the Camry include the Honda Accord, Nissan Altima, Ford Fusion, and Hyundai Sonata. For 2011, the Camry received a redesigned gas pedal problems with gas pedals triggered the recalls as well as a new brake override system, designed to prevent the Camry from accelerating when the drivers foot is depressing the brake. Trims range from the entrylevel Base trim to the LE, sporty SE, and highend XLE. A 2.5liter fourcylinder engine, producing 169 hp and 167 lbft of torque 179 hp and 171 lbft for the SE, provides base power for all trims, although owners can upgrade to a 3.5liter V6 engine, which pumps up the power to 268 hp and 248 lbft of torque. The Camrys platform and size, however, should remain the same as the current versions. Available as both a fourdoor sedan and a fivedoor hatchback, it stretched to 102 inches, making it one of the longer Japanese imports. In the Toyota lineup, the frontwheeldrive Camry slotted above the Corolla and the rearwheeldrive Corona, which it replaced in many markets, including the U.S. Power came from a 1.8liter, 92hp four cylinder, which did a good job of moving the fairly lightweight Camry. Toyota offered early Camrys with either a fivespeed manual or a fourspeed automatic transmission. Even in its first generation referred to internally as the V10, the Camrys comfortable ride, quiet interior, good gas mileage, and affordability attracted buyers worldwide. Like the original Camry, this version had a narrow body and carried the compact car designation. In all, Toyota launched five generations of the narrowbody Camry, with the third generation V30 appearing in 1990, the fourth V40 in 1994, and the fifth the V50 in 1998. However, the latter generations of the narrowbody Camry were not available in the U.S. market, since they were replaced in 1992 by a longer, widebody platform, which moved the Camry into the midsize market segment, where it remains today. In 1988, the automaker offered Camry trims with a new optional 2.

5liter, 158hp V6 powerplant and an allwheeldrive system called AllTrac. That same year, Toyota started building Camry Base, DX, and LE trims at a new plant in Georgetown, Kentucky. Although the wheelbase of the first widebody generation dubbed XV10 stretched only 1 inch longer than the narrowbody version, overall it was 6 inches longer and two inches wider than its predecessor. It also received a larger 2.2liter fourcylinder engine developing 130 hp, while the V6 was beefed up to 3.0 liters and generated 185 hp. Also in 1992, antilock brakes became optional. It reemerged in 1999 as the Camry Solara, and was designed primarily to compete with the Honda Accord Coupe. Toyota also added a passengerside airbag for the Camry in 94, and introduced sideimpact airbags as an option for all Camrys in 1998. Once again, for this generation, Toyota stretched the Camrys

dimensions, adding 2 inches to its wheelbase and 2.5 inches to its height. The automaker bumped horsepower for the V6 engine to 192 and introduced a new 2.4liter fourcylinder powerplant producing 157 hp and 162 lbft of torque. In addition, Toyota dropped the station wagon from the Camry lineup, in deference to the growing influence of SUVs. Such features as power door locks, stability control, and traction control became standard on all Camry trims in 2010. Numerous awards helped build the Camrys appeal, including Motor Trends Car of the Year award in 2007 and more Best Car for the Money awards than any other model, according to the automaker. In addition, the Camry was the bestselling car in America for 12 of the last 13 years, and had the best resale value of all cars in 2010, according to Kelley Blue Book, attesting to the cars value, affordability, and popularity with buyers. The voluntary safety recall for problems with gas pedals affected certain Camrys built from 2007 to 2010, especially fourcylinder trims. In addition, certain Camrys built in the same year were recalled due to issues with the floor mats.

<http://eco-region31.ru/3m-x90-manual>