



File Name: canon rebel film camera manual.pdf

Size: 1961 KB

Type: PDF, ePub, eBook

Category: Book

Uploaded: 25 May 2019, 19:41 PM

Rating: 4.6/5 from 648 votes.

Status: AVAILABLE

Last checked: 19 Minutes ago!

In order to read or download canon rebel film camera manual ebook, you need to create a FREE account.

[**Download Now!**](#)

eBook includes PDF, ePub and Kindle version

[Register a free 1 month Trial Account.](#)

[Download as many books as you like \(Personal use\)](#)

[Cancel the membership at any time if not satisfied.](#)

[Join Over 80000 Happy Readers](#)

Book Descriptions:

We have made it easy for you to find a PDF Ebooks without any digging. And by having access to our ebooks online or by storing it on your computer, you have convenient answers with canon rebel film camera manual . To get started finding canon rebel film camera manual , you are right to find our website which has a comprehensive collection of manuals listed.

Our library is the biggest of these that have literally hundreds of thousands of different products represented.



Book Descriptions:

canon rebel film camera manual

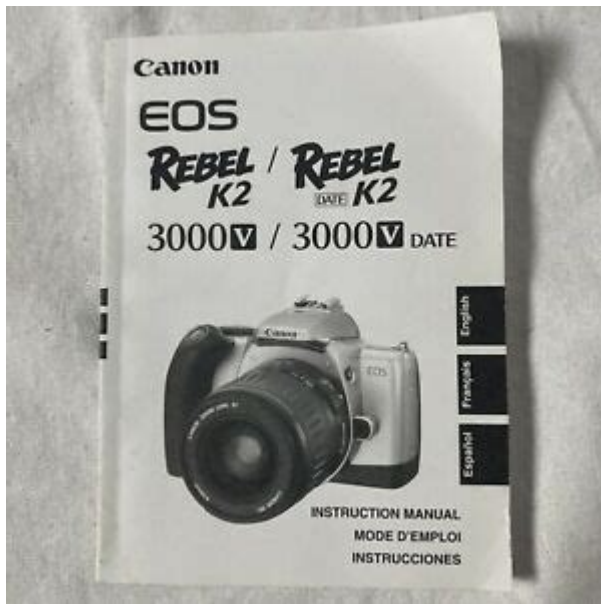

It'll make you feel better, won't it. If you use Pay Pal, use the link below. Use the above address for a check, M.O. or cash. NOTE they only print in Black and White. This page requires Javascript. Modify your browsers settings to allow Javascript to execute. See your browsers documentation for specific instructions. To install your download click on the name of the downloaded file. The shutter does not release until focus is achieved. OneShot AF Autofocus locks when focusing is achieved. AI Servo AF For automatic switching between OneShot AF for stationary subjects and predictive AF for moving subjects. Manual Focus Setting the lens focus mode switch to MF enables manual focusing with the focusing ring. Three metering patterns available. Evaluative metering. Central partial metering which covers approximately 9.5% of the finder area. Center weighted average metering Set automatically in M mode. ETTL 7point, 35zone through the lens flash metering used exclusively with EX series EOS Speedlites. ATTL, TTL Flash Metering; 3point, 4zone off the film flash metering used with built-in flash and all EOS Speedlites except EX series. Automatically clears upon completion. Cancelable midway. Auto popup and serial controlled. The flash ready icon lights in the viewfinder when ready. After film positioning and back cover closure, the film automatically winds to the first frame. Quiet Film Transport Film winding sound level approximately 60 db. Subject to change without notice. Recommended Software File Name Date File Size Optional Software File Name Date File Size Recommended Manuals File Name Date File Size Optional Manuals File Name Date File Size The Limited International Warranty is only effective upon presentation of the warranty card and proof of purchase. Equipment covered by this Warranty will be repaired by Canon International Warranty Members located in the United States, Canada, Australia, the United Kingdom and New Zealand WITHOUT CHARGE. <http://www.podhoru.cz/userfiles/duravit-sundeck-manual.xml>

- **canon rebel film camera manual.**

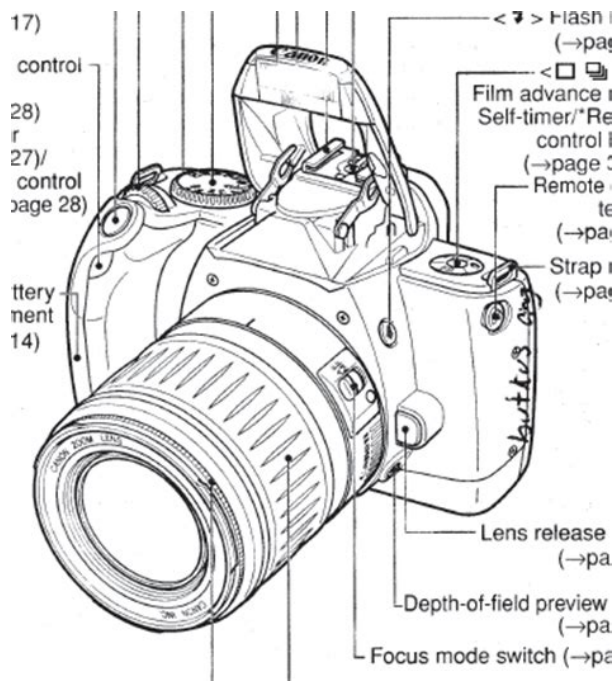

List of Canon International Warranty Members included with the equipment. Equipment covered by this Warranty will be repaired by Canon International Warranty Members WITHOUT CHARGE, except for insurance, transportation and handling charges. See list of Canon International Warranty Members included with the equipment. When returning equipment for warranty service, the shipping charges must be prepaid and the equipment should be shipped in its original carton or box, or an equivalent, properly packed to withstand the hazards of shipment and be fully insured. A copy of this warranty card and proof of purchase should be enclosed, as well as a description of the problem, film samples, etc. This warranty only covers defective materials or workmanship encountered in normal use of the equipment, and does not apply in the following cases Fred Thomas Drive, P.O. Box 33336, Takapuna Auckland Canon UK Ltd. Brent Trading Centre. North Circular Road Neasden, London NW10 OJF Canon U.S.A., One Canon Park, Melville, NY 11747 The above address is not to be used for the MAILIN SERVICE program Scroll down to easily select items to add to your shopping cart for a faster, easier checkout. Visit the Canon Online Store Adapter EcC, EdC With three lens elements in three groups, chromatic aberration and distortion are effectively corrected to give crystalclear images. Eye fatigue is not a problem even after prolonged use.Holds 12 Cameras bodies, 34 lenses and accessories. Inside measurements W x H x D 10 x 14.75 x 5 inches. Rugged nylon, waterrepellent, urethane coated for extra durability. Wellarranged divider system for secure storage and easy access. Lightweight construction, padded shoulder straps and back for comfort. Front webbing ideal for storing a light jacket. Tripod carrying straps. Color Black with Olive.Front and Rear zippered pouches. Zippered fulllength mesh pouch inside top cover. Divider system for secure storage and easy access.<http://www.parasitenberatung.at/userfiles/durbin-modern-algebra-solutions-manual.xml>

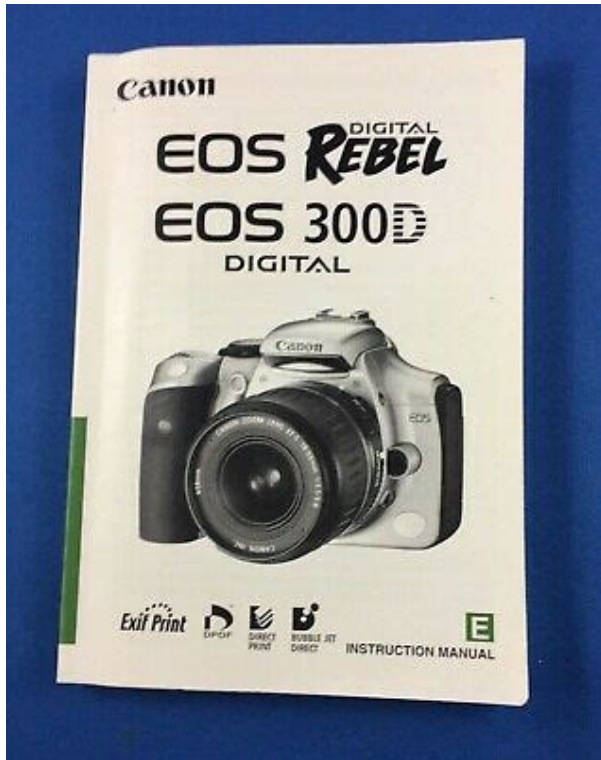

It is designed to hold two 35mm SLR bodies, 5 8 lenses, plus film and accessories. It features a 3way pan head for precise control and smooth movement. The 3section tubular leg construction allows for exceptional stability indoors or out. The Deluxe Tripod 300 features a 3 way pan head for precise control while the 3 section tubular leg construction allows enhanced stability indoors and outdoors. The lens fits into the eyepiece holder of you EOS camera. Please see the Compatibility tab for a list of compatible EOS cameras. The lens fits into the eyepiece holder of you EOS camera. The lens fits into the eyepiece holder of you EOS camera. The lens fits into the eyepiece holder of you EOS camera. The lens fits into the eyepiece holder of you EOS camera. The lens fits into the eyepiece holder of you EOS camera. Requires Rubber Frame Ef, Eb or Ec The lens fits into the eyepiece holder of you EOS camera. Made from Cordura Nylon. Large Zippered Front Accessory Pocket. Zippered Mesh Pocket Inside Top Lid. Two Side Accessory Zippered Pockets. Tripod Loops on Bottom. Five Movable, Padded Internal Dividers. Two Strap Handles with Grip. Removable Shoulder Strap. Rubber Feet for Ground Protection. It features a foam grip on the top leg section, a hand strap, flip lock leg sections, and rubber leg tip. Features adjustable tripod straps, and high strength buckles for the main compartment. The Canon logo is embroidered on the top flap. Interior Padding for Cushioning. Front Zippered Accessory Pocket. Touch Fastened Closure. Shoulder Strap. It was succeeded by the New EOS Kiss EOS Rebel XS or 500 in other countries. The focusing point can be selected manually by the user or automatically by the camera. Focusing the desired subject can be as quick as a more expensive camera.

The following picturetaking modes can be set Shutter speedpriority AE, aperturepriority AE, shiftable Intelligent program AE, Programmed Image Control modes, depthoffield AE, program flash AE, and metered manual. The camera comes in silver or black. Three focusing points selectable by dial operation or by the camera automatically. Hot shoe provided for flash sync. Built in electronic selftimer. Blinking shutter speed display is a camerashake warning. Three focusing points superimposed, infocus indicator, exposure display dots exposure compensation amount, metered manual exposure, autobracketing amount, redeye reduction lampON indicator, flash ready, highspeed sync, shutter speed setting and control value, and aperture setting and control value are displayed with a yellowgreen LED. Panorama frame New EOS Kiss only. Maximum 9 multiple exposures cancellable manually. Retractable head. TTL autoflash control fires automatically in

backlight and lowlight conditions in the Full Auto and three Programmed Image Control modes with offthefilm metering. Flash sync speed set automatically anywhere from 30 sec. Fillflash enabled. Redeye reduction lamp provided. With the optional Canon Speedlite 220E or 380EX, the camera's AE lock button fires a preflash. The resulting reflection off the subject is metered partial metering at center by the AE sensor to determine the flash output. FE lock can also be controlled in this way. Guide No. 12 at ISO 100 in m. First, the entire roll is wound on the takeup spool. Then each time a picture is taken, the film advances back into the cartridge. Film transport with the builtin motor. Film advance speed 1 fps. After the last frame is exposed, the film is rewound automatically. Midroll rewind enabled. Each interval represents a 15 day period. There is no guarantee that items will always be listed at a price within the provided range. Having said that this camera is fast. Super quick focus and film advance. Its a film camera that resonds like a DSLR.

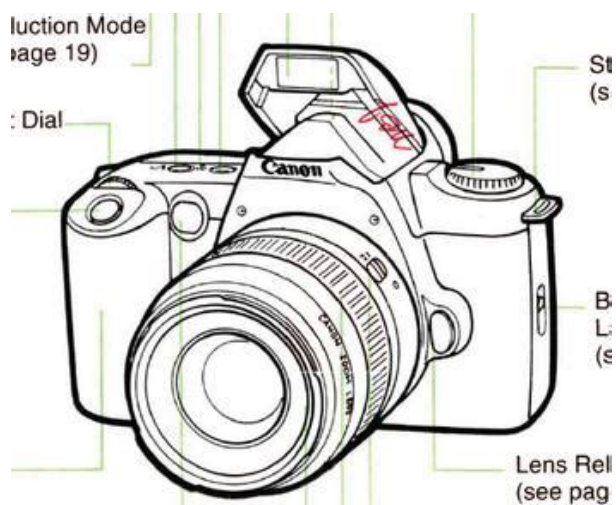

<http://superbia.lgbt/flotaganis/1649381241>

Its small and compact for an SLR and a great camera for those just getting into film photography.. Read full review Read less Verified purchase Yes by goodoljack April 25, 2018 Solid little film slr The Canon EOS Rebel 2000 was one of the last great film cameras before the digital revolution. It is a really great little camera. Its super lightweight and has a lot of great features. The image quality of the Rebel is top notch, and with the ability to scan negatives and being able to archive your developed negatives, your images are protected forever. No worrying about when, not if, that hard drive is going to crash; because it is going to crash. Negatives saved in albums are forever. On of the many reasons so many people are coming back to film.. Read full review Read less Verified purchase Yes by charlesosborne2002 September 13, 2017 Just what I wanted I was delighted with this, and surprised at how light it was for a full frame SLR. I wanted something for full frame and could not afford digital. I have a Canon digital 650D like the Rebel series, so the Canon EF lenses work on both, or my M42 screw mount manual lenses with adapter work on both. Most of the features are alike in operation. For important photos I can shoot APSC in digital and full frame with film.. Read full review Read less Verified purchase Yes by bdiana46 March 02, 2017 Cannon EOS Rebel 2000 The picture quality is amazing for the pictures I need to take for my photography class and the camera is in a surprisingly excellent condition. It had a full battery, all of the buttons and nobs worked, and hardly any scratches on the camera so it was almost like new. I like that this camera has an automatic and manual program to choose from. Unless you dont know how to work the iOS, exposure and shutter speed then automatic is for you.. Read full review Read less Verified purchase Yes by lcml dau4lf1ia July 05, 2016 I love it. Best film camera I ever had the pleasure of working with.

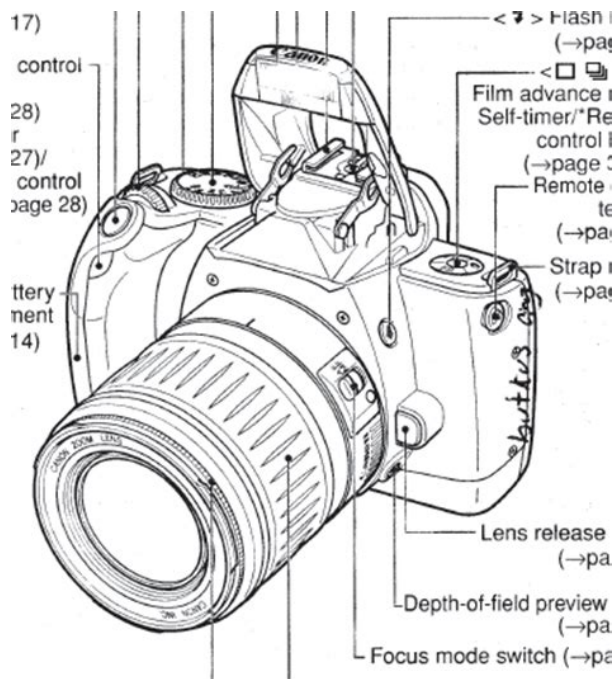

Its feel light and nice on my hand. Easy to use and has automatic focus. The only thing that I may not like is the sound it makes when I photograph someone without them noticing. Other than that it the best camera ever!. Read full review Read less Verified purchase Yes Show more Show less by jke6344 August 13, 2011 Very disappointing I have used 2 rolls of film and the quality of the prints is poor. The pictures are grainy and grayish. The color is poor. I am very disappointed in the product esp. Next, open the back of the camera by sliding To manually set the Next, turn the main control dial bottom Cap the rear of the lens you have just Place the new Be sure the lens is firmly Be sure the lens that you removed is In the illustration, the camera is set at This will activate the Look through the There are also 3 The camera will A blinking number in the You can select the left, The focusing point that is If all three boxes are shown, This will cause the timer icon to Look through the viewfinder, compose Press the exposure You can adjust the Partial metering Press the function button The exposure meter red Next take three pictures of the Rotate the main Press the function Rotate the main dial to Note that you will need Of course, you will have to In the P, Tv or Av This indicates the flash is Although they may If you have taken 10 shots You can now take pictures. I may also earn commissions from links to other online retailers. You can see the full disclosure here. Introduced in 1990, the Canon EOS Rebel is the first camera to have the Rebel branding. The Canon EOS Rebel S is the same camera, but with a built in flash. In Europe the camera was called the Canon EOS 1000F and EOS 1000F QD. Both of those had a built in flash, with the QD model having a quartz date back. In Japan the camera was released as the Canon EOS 1000F QDP. The P designated that the camera had a panorama mode. The camera was replaced in 1992 by the Canon EOS Rebel II and Rebel SII. Table of Contents.

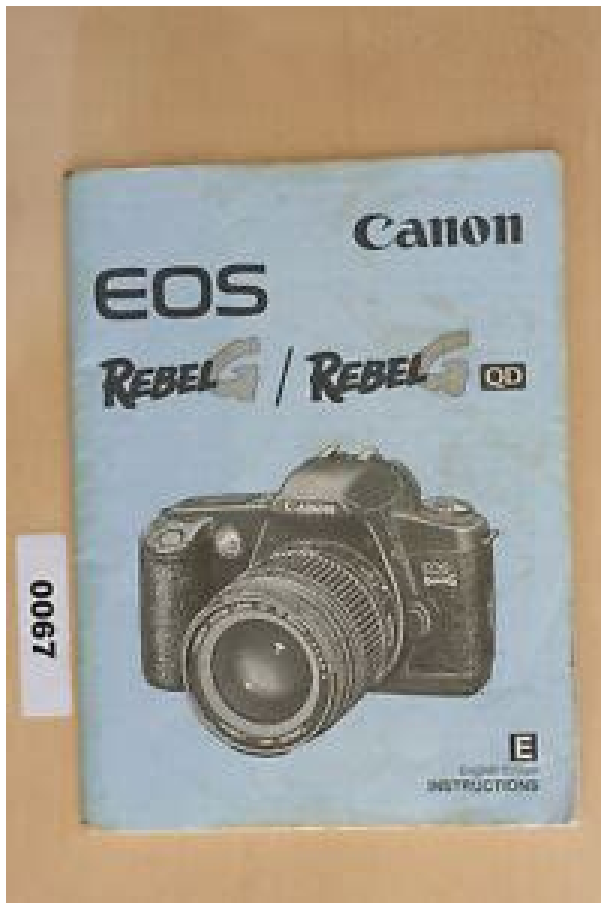

This battery can be found in most stores, but it is expensive. Later models such as the Canon EOS Rebel G, use 2x CR123A batteries. These are less expensive and rechargeable versions are available. Unlike mechanical cameras, such as the Canon FT QL, the Rebel needs a battery in order to operate. The best practice is to always have an extra battery with you, otherwise, your photography might come to an abrupt end. Thrift stores, garage sales, Craigslist, Facebook groups, and online. Plus, many cameras available will be bundled with additional Canon lenses and accessories. Your best option is to check the current eBay prices. The camera and a kit lens should not be expensive. Canon EOS Rebel G Manual A PDF scan of the Canon EOS Rebel manual can be found on Butkus.org. The manual is great to have in case you don't understand a specific feature of the camera. There is a bulb mode for long exposures. Using the bulb mode will drain the camera battery, as power is used to keep the mirror up and shutter open. Depending on how long your exposure is going to be, you may want to use a new battery. Don't risk having your shot ruined and time wasted because you didn't use a fresh battery. The camera also has an electronically controlled 10 second self timer. When activated the camera will slowly beep. Towards the end of the countdown the camera will beep at a faster rate. Shooting Modes All of the advanced exposure modes you would expect from a modern camera are present. The Canon Rebel has Auto Exposure Aperture Priority Shutter Priority Program Mode Manual Mode There are 4 Auto Program shooting modes. These modes use settings that will give a better result than auto for specific types of scenes. They are Portrait Landscape CloseUp Action Continuous Frame Rate The Canon EOS Rebel is able to shoot continuously at about 1 fps. That's not very fast, but then again it is not the type of camera you'd want to use for burst shooting.

If you want a camera capable of a faster frame rate, look for a Canon Elan 7. What Kind of Film Does the Camera Use. The Canon Rebel uses 35mm film. This is the most common film available. The light tight metal cassettes make it possible to load the film in the daylight. You might be able to find rolls for sale at Walgreens, CVS, Walmart, and other stores. Those same stores will also be able to develop the film for you. However, they no longer do the development in store. They mail the film off to a lab to be developed and you will not get your developed negatives back. You don't need to use a

store to develop your 35mm film. Instead you can just mail the film off yourself to a photo lab, such as The Darkroom. What film to use 400 ISO is my default recommendation for any camera. The film is fast enough to use indoor and shade. Film with a lower ISO, like 100, requires more light to expose properly. This means using a larger aperture or longer shutter speed if you're not in sunlight. Unless you get the Rebel S, not having a built-in flash is going to make things difficult. It would be better to buy a newer camera in the Rebel line than a flash. Unless you are going to be in full sun or use a flash, I would advise against using ISO 100 film. If you will have lots of light or are comfortable with using a flash ISO 100 film will produce images with less grain than ISO 400 film. Newer cameras can not use infrared film because they have infrared sensors to control the automatic film advance. The sensors will fog the film, making it unusable. Film ISO Settings The camera has an ISO range of 255000 for DX-coded film. The automatic ISO setting from the DX-coded film can be overwritten through the same process needed to set the ISO for non-DX-coded film. For non-DX-coded film, the ISO can be manually set from 66400. This is done by setting the control dial to the ISO setting and rotating the command dial. One benefit is that a pentamirror weighs less.

<http://www.oknookna.pl/wp-content/plugins/formcraft/file-upload/server/content/files/16272c0aac2401---brewstation-48464-manual.pdf>

The light weight will make the camera more enjoyable to carry around and is fine for casual shooting. Metering is center weighted. This is standard for all film cameras released in the previous 2 decades. There are no problems with the camera's ability to select the correct exposure. Auto Focus The camera has 1 autofocus point. You're going to have to focus on your subject and recompose to get attractive photos. This can be done through the focus lock. If you do not have previous experience with film cameras, this will be a departure from using a modern digital camera. Canon EF Lens Mount Any Canon EF lens can be used on the camera. These are full-frame lenses that can also be used on Canon DSLRs. Compatible Canon EOS lenses will have a red dot indicating the correct position for mounting the lens to the camera. EFS lenses designed for DX digital cameras will not work. The lens mount looks similar to an EF lens. You can tell the difference because EFS lenses have a white square to indicate where to mount the lens. Recommended Lenses to Use The lenses recommended are in line with the cost of the camera. If you want the best performance for the money, get a 50mm or 28mm prime lens. Zooms are easier to use, but the image quality will not be as good as you can get from a prime. It is useful if you have large hands, but may be difficult to find for sale. Canon Speedlites These are the Speedlites that Canon listed in the camera manual for use with the Rebel. Turning the input dial will allow you to specify how many exposures you want. The maximum you can do is 9. Once set you can press the shutter button to begin taking the series of multiple exposures. After all the exposures have been taken, the film will advance to the next frame. To clear the preset exposures, repeat the steps, and set the number of exposures to 1. My Short Review of the Camera Overall, I would give the camera 2 stars out of 5. My problems with the Rebel come down to the camera cost.

The battery is expensive. Newer cameras in the Rebel line are also similarly priced and have better autofocus. In my testing, the Rebel had problems focusing indoors, in shade, and with low contrast. The camera would hunt for focus, making it slow when it was able to find focus. When tested against the Rebel G, which is a few generations newer, the difference was significant. The body of the Rebel is also larger and heavier than the later models. This would be fine if it offered weather sealing, but it doesn't. Too many improvements were made to later generations of the camera for me to recommend the original Rebel to anyone. The Rebel T2 is the best choice for an entry-level Canon EOS 35mm film camera. Released in 2004, the Canon EOS Rebel T2 has 7 auto focus points, a higher frame rate, accurate autofocus in low light, better focusing speed, and a higher quality build than the Rebel. It is also 14 years newer, so reliability should be better. Canon EOS Elan 7 Europe EOS 30, Japan EOS 7 Released in October of 2000, the Canon EOS Elan 7 is a big step up in terms of

build quality and features. It was targeted towards enthusiasts and advanced amateurs. The EOS Elan 7 can be hard to find. Avoid the Elan 7e or EOS 33 as they have eye movement controlled autofocus detection. You're supposed to look into the viewfinder at the focus point you want instead of needing to manually select the focus point. The eyecontrolled focus point detection did not work well. It was never included on any of Canon's other cameras. Nikon N65 The N65 was a competitor to the Canon EOS Rebel 2000. Notable differences are the better build quality, faster frame rate, and the Nikon F lens mount. A good choice if you own F-mount lenses. Check out the Nikon N65 Camera Review. Used Very Good With AF Zoom Lens. Battery and film not included. Something we hope you'll especially enjoy. FBA items qualify for FREE Shipping and Amazon Prime. Learn more about the program. Please try again. Please try again.

Page 1 of 1 Start over Page 1 of 1 In order to navigate out of this carousel please use your heading shortcut key to navigate to the next or previous heading. In order to navigate out of this carousel please use your heading shortcut key to navigate to the next or previous heading. In order to navigate out of this carousel please use your heading shortcut key to navigate to the next or previous heading. Register a free business account Please try your search again later. Fully loaded with both automatic and manual features for superior performance and easy operation, the GII gives you a unique combination of intelligent, simple and silent operation with sophisticated SLR performance. This kit comes complete with a high-quality interchangeable Canon EF 35-80mm zoom lens. Compact and extremely lightweight, the fully automatic Rebel G II features a retractable built-in flash with red-eye reduction, a high-speed selectable 3-point autofocus system, and settings for multiple exposures and other creative effects. It offers 11 exposure modes full auto to metered manual with indicator plus multiple exposure, exposure compensation, and autoexposure bracketing. The new Night Scene mode combines the perfect balance between natural light and flash for stunning portraits at sunset. The camera measures 5.7 x 3.6 x 2.5 inches and weighs 12.35 ounces without batteries and 13.45 ounces with batteries loaded. Canon engineers were able to incorporate some of the most advanced camera functionality available in this entry-level SLR camera including; 11 exposure modes, a 3-point autofocus system, Auto Exposure Bracketing, manual focusing point selection in the viewfinder and settings for multiple exposures and other creative effects.

Fully automatic 35mm SLR camera with built-in flash Selectable wide-area 3-point AF 11 shooting modes including 5 PIC modes Accepts all EF lenses and many EOS system accessories To calculate the overall star rating and percentage breakdown by star, we don't use a simple average. Instead, our system considers things like how recent a review is and if the reviewer bought the item on Amazon. It also analyzes reviews to verify trustworthiness. Please try again later. Donna 5.0 out of 5 stars The company that I purchased it from I feel had it at a fair price I had a couple of questions regarding my purchase like if the camera came with a strap and it does when leaving the message I was told it could take up to 2 business days to get a reply I got an immediate response to my question. Jamie is the person that assisted me went above and beyond and went the extra mile by answering my questions so quickly with extra perks at no cost to me. If you are looking for a camera I highly recommend this company. They also informed me that even when I go beyond my time frame if I choose to return the camera or not that I can still reach out if I need assistance with it. Now I have to go out and find the right battery so she can use it for her class. Pictures came out so wonderfully and the zoom and focus are amazing. Great purchase! Has a meter for lighting on the screen of the camera and many more settings. Mine came with 80mm, carrying strap and manual. The seller was the best and mailed me everything as stated in description. I emailed him that I needed it sooner and so as soon as I purchased it, he mailed it next day USPS. It's a perfect beginner camera. Thank you! It arrived my photography said everything was in good condition. Perfect for my film class this semester. Aperture and shutter speed worked fine. This was my first purchase for a camera I'd say it was a good experience! My daughter uses it for photography class in school. Used Good Included 2880MM AF Canon lens.

Battery and film not included. Something we hope you'll especially enjoy. FBA items qualify for FREE Shipping and Amazon Prime. Learn more about the program. Please try again. Please try again. In order to navigate out of this carousel please use your heading shortcut key to navigate to the next or previous heading. Page 1 of 1 Start over Page 1 of 1 In order to navigate out of this carousel please use your heading shortcut key to navigate to the next or previous heading. In order to navigate out of this carousel please use your heading shortcut key to navigate to the next or previous heading. Register a free business account Please try your search again later. It offers a host of special modes for specific shooting situations, including full auto, manual, night scene, portrait, landscape, and more. It also has shutter speed priority and aperture priority modes although most users will inevitably leave the camera in full auto mode a majority of the time and the camera performs very well that way. Just remember that the empty rectangle symbol on the mode dial is for full auto. Some other basic features include an impressive seven-point autofocus system, LCD panel with extensive information display, three exposure metering modes evaluative, partial, and center-weighted, auto exposure bracketing, a multiple exposure function, and depth of field preview. The autofocus system is incredibly responsive, and includes seven focusing points that can be set individually for super creative shooting. In other words, using the LCD panel as a guide, you can set the camera to automatically focus on the far right focus point or any of the other points so your main subject doesn't have to be in the middle of the frame to be in focus in a snap. In fact, most settings can be adjusted in creative ways on the Rebel 2000, like the exposure level, which can be set to overexpose or underexpose up to two full stops for tricky lighting situations where you might want to fool the camera's metering system.

It also has a small, built-in popup flash, plus a hot shoe for an additional flash unit. Overall, we found this camera to be smartly designed with an attractive look and a comfortable feel. With its convenient built-in retractable flash and 11 versatile shooting modes, the EOS Rebel 2000 lets you get great photos of vacations, sporting events, landscapes, portraits and more. Smaller and lighter than ever before, the EOS Rebel 2000 incorporates a full range of basic features including depth of field preview, scale metered manual exposure and 10 other shooting modes. Advanced features include a choice of evaluative or partial metering patterns, AE lock, Auto Exposure Bracketing, multiple exposure and more. The EOS Rebel 2000 is also fully compatible with all EF lenses and EOS Speedlites, including Canon's latest EX series with ETTL, FE Lock and High Speed Sync modes for incredible flexibility in creative flash photography. Fully automatic 35mm AF SLR with retractable built-in flash. Smaller and lighter than ever before, with faster AF, quiet operation and many other improved functions. High speed selectable 7-point autofocus system linked to 35-zone metering system for available light and flash. Supports advanced flash metering system features including ETTL, FE Lock and High Speed Sync modes with EX series Speedlites. Full range of basic features including remote control socket, depth of field preview, scale metered manual exposure and 10 other shooting modes. Creative controls include a choice of evaluative or partial metering patterns, AE lock, Auto Exposure Bracketing, multiple exposure and more. To calculate the overall star rating and percentage breakdown by star, we don't use a simple average. It also analyzes reviews to verify trustworthiness. Please try again later. Susan Henry 5.0 out of 5 stars I didn't realize this didn't come with a special battery. I bought it for my daughter for Christmas and she still hasn't been able to use it because I can't find the battery anywhere.

It does come with a roll of film though. It arrived on time and the packaging was secure. Now if I can just find a battery! I purchased the Canon Rebel 2000 to see how different the use is compared to my Pentax. I love this camera! It's automatic, so it is very easy to use. All of my pictures have come out amazing so far. Package came with camera body batteries already inside, lens, Canon strap, and two rolls of Fujifilm. Would recommend to anyone who's looking to take some great and easy film photos. The camera is in excellent condition and I was a little apprehensive buying a used camera but I am certainly not disappointed. The camera is in excellent condition and is just perfect for this

class. My son is having a lot of fun learning how to use it. I also thought that the price was reasonable. Thank you! My first one's back case broke on its own which forced me to use tap to close the case. I bought a second one and it served me very well, it does struggle in autofocusing and it doesn't help you as much with lowlighting situations. Still, it brought out an excellent quality of my photographs. Because it is used, the LCD is dim, and the buttons stick a little; I am confident it will last for a much longer time. I loved it so much that I had to buy it again. I love that you can switch between automatic and manual modes, and there is even a built-in flash. You don't find many high quality film cameras with these features that are also affordable. Thanks Canon! The Canon Rebel 2000 is easy to operate from the first day you get it. It lets you be a point and shoot user with a smart camera or a smart photographer with control over the manual settings. Since other reviews of this product have focused on the many fine features on this camera, I wanted to mention the one thing that I had not seen printed about this product. The Canon Rebel 2000 Kit comes with a strap and 2 lithium batteries to get you started.

<https://www.becompta.be/emploi/bosch-sgs45e08gb-manual>